

nanoPVD-T15A

Thermal evaporation system for metals and organics



Key features:

- Benchtop configuration
- Up to 4 LTE sources for organics
- Up to 2 evaporation sources for metals
- High aspect-ratio chamber for uniform coating
- Up to 4" diameter stages
- Sample heating option
- Source and substrate shutters
- Fully automatic operation via touchscreen HMI
- Base pressures $< 5 \times 10^{-7}$ mbar
- Define/save multiple process recipes
- Easy servicing
- Comprehensive safety features
- Cleanroom compatible
- Proven performance

MOORFIELD
— NANOTECHNOLOGY —

 A Judges Scientific company

Overview:

nanoPVD systems are compact and suitable for benchtop location — but not to be confused with microscopy-related products — and are derived from proven R&D thin-film system technology. They have been developed through extensive collaboration with leading academic groups.

The tools are optimised for ease of use, represent outstanding value for money and are ideal where available space and budgets are key considerations — without compromising on quality of results.

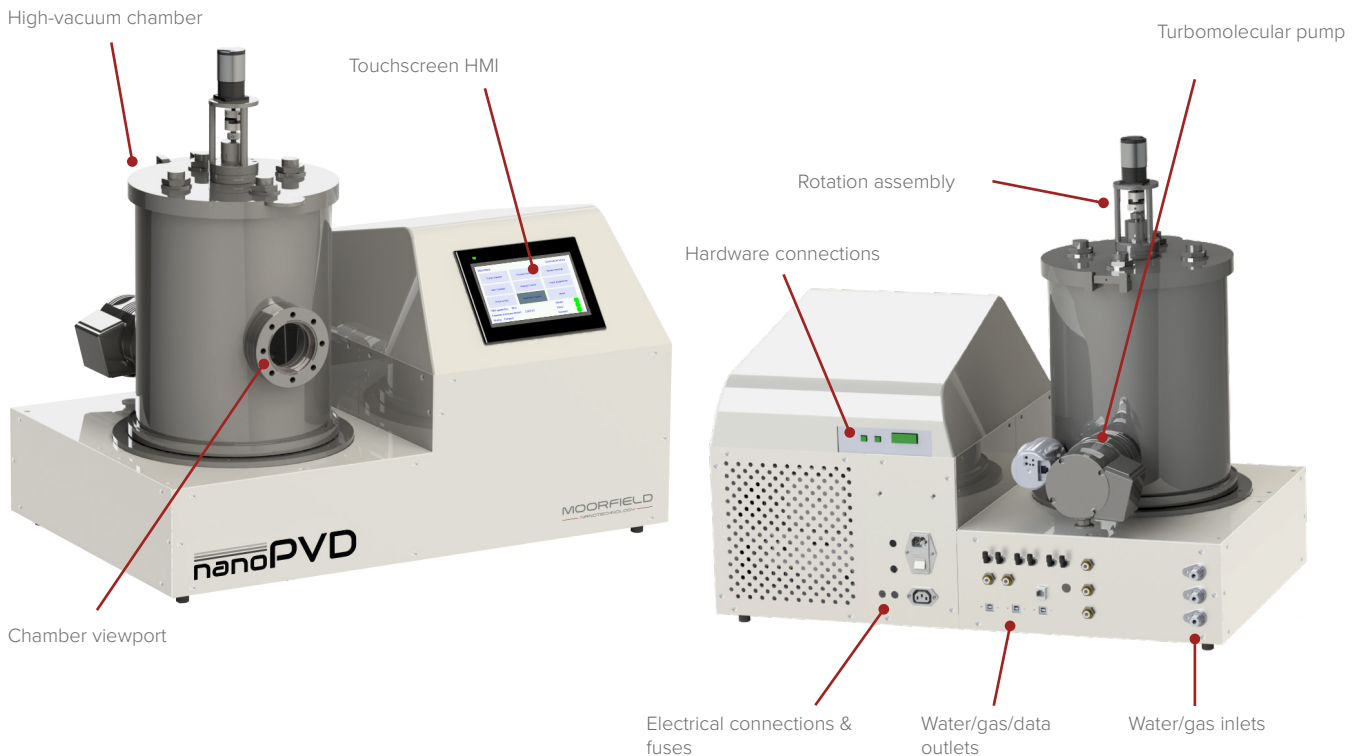

Model nanoPVD-T15A:

Model T15A is a thermal evaporation system designed for repeatable coating with organics and/or metals. At the heart of the system is a modular process chamber. The chamber is designed for easy disassembly for routine maintenance. At the rear of the vacuum chamber is a port for the pumping system. The pumping system is based on an Edwards turbomolecular pump that is connected to a rotary or scroll-type backing pump.

Chamber access is via a hinged top lid. Opening the lid reveals the substrate stage, which can hold substrates up to 4" diameter. The stage can also be fitted with a heater, for platen temperatures up to 500 °C, and substrate rotation.

For organics, the system can be equipped with low-temperature evaporation (LTE) sources that offer control for temperatures ≤ 600 °C, ideal for working with low melting-point materials. LTE sources can be fitted with alumina or quartz crucibles (2 CC internal volume; suggested 1 CC charge). Replacing crucibles is a straightforward operation.

For metals deposition, the unit is fitted with standard thermal evaporation sources. These are boxed sources (efficient operation and restricted stray IR and cross-contamination) that are capable of accepting industry-standard basket, wire or boat material supports.

Possible configurations are up to 4 sources, with a maximum of 2 of these being for metals. All source positioning is optimised for uniform deposition onto the 4" substrate stage. Combination systems with both organics and metals sources allows for all key OLED/OTFT/OPV device fabrication steps within one tool.

Quartz crystal sensor heads (with PC software) allow for deposition rate and thickness monitoring.

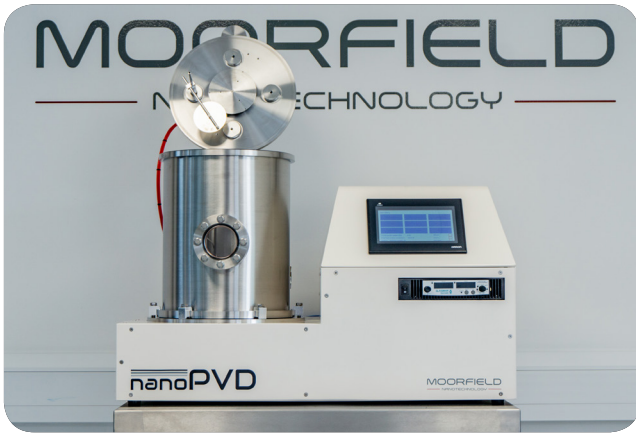

The nanoPVD-T15A system with its chamber opened

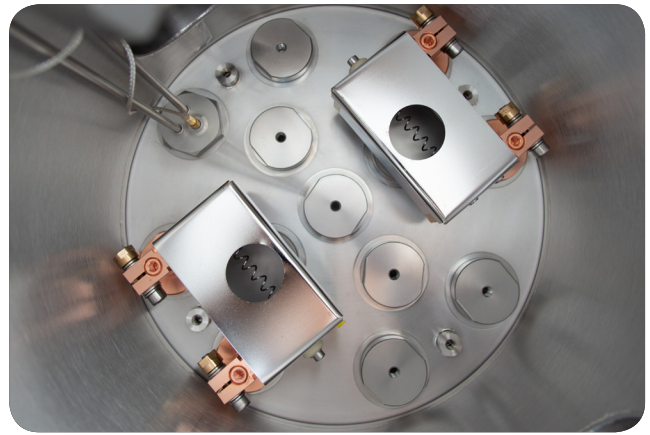

Chamber interior with 2 thermal evaporation sources for metals

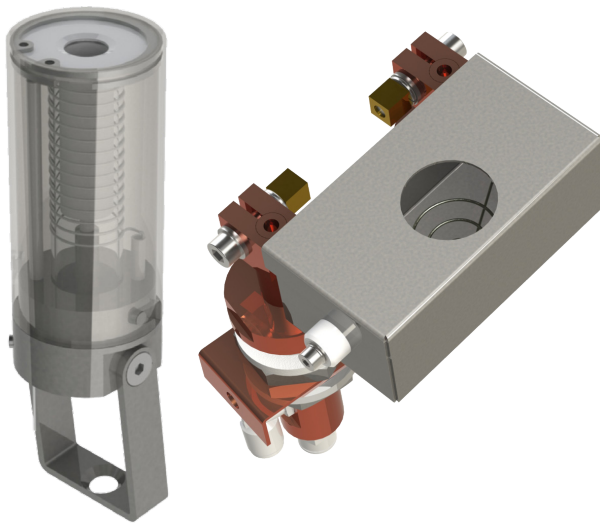

Evaporation source types that can be fitted to the nanoPVD-T15A

- Low-temperature evaporation (LTE) source for organics (far left).
- Standard thermal evaporation source for metals (left)

Control system:

The unit is fitted with high-stability, industrial-grade PLC electronics. User operation is via a 7" touchscreen HMI mounted on the front panel. Powerful but easy-to-use software allows for system setup and operation via a menu-driven interface. Users are able to edit, save and load multiple recipes rapidly. Recipes and live data can be logged to a connected PC.

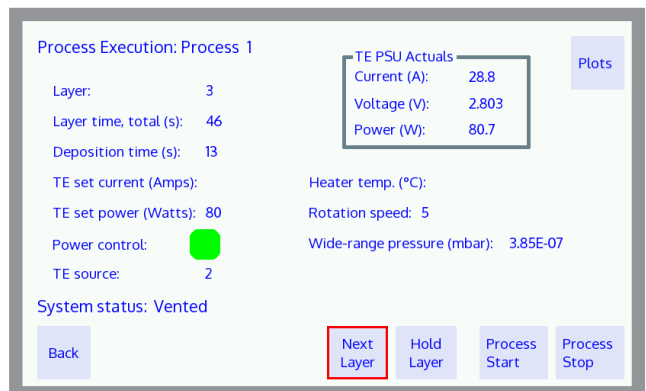
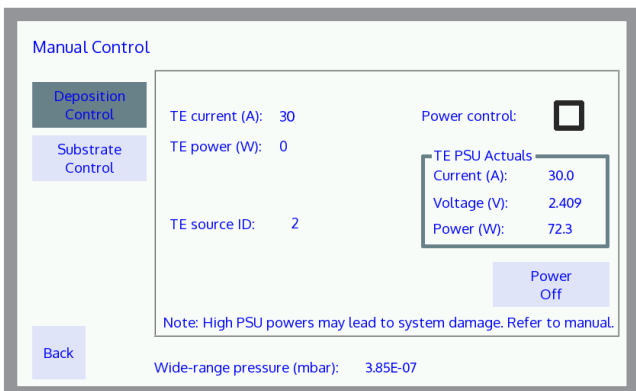

Screenshots from the touchscreen HMI software through which all user operation of the nanoPVD-T15A is carried out

Options:

The standard configuration for the nanoPVD-T15A includes the chamber, pumping system, frame and electronics. To obtain a working system, it is necessary to select at least one metals or organics source, up to a maximum of four (mixed source types allowed). Beyond this, a variety of options allow the tool to be configured per specific budgets and applications:

- Dry backing pump
- Chamber viewport
- Fast chamber vent
- Substrate rotation
- Substrate Z-shift
- Single substrate shutter for 2" substrates
- Dual substrate shutter for 4" substrates
- Source shutters
- 500 °C platen heating
- Up to 4 LTE sources for organics
- Up to 2 evaporation sources for metals
- Quartz crystal sensor head

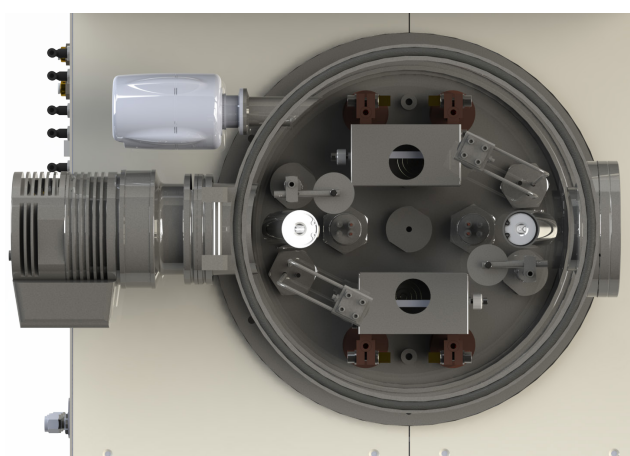
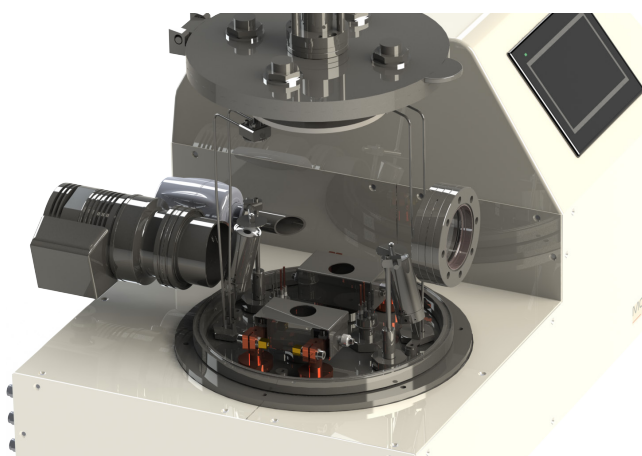

Models of the nanoPVD-T15A configured with two LTE sources for organics and two sources for metals. The system shown is also fitted with quartz crystal sensor heads for monitoring of deposition rates and thicknesses.

System requirements: (standard configuration)

- Service gas: Dry compressed air nitrogen or argon, 60–80 psi supply
- Power: Single-phase 230 V, 50 Hz, 10 A
- Coolant: 18–20 °C, 1 L/min, pressure < 4 bar
- Exhaust extraction

Applications:

- Fundamental research
- Education
- Product R&D

All images/descriptions in this brochure are indicative only; final appearance and design subject to your exact configuration.

MOORFIELD
NANOTECHNOLOGY

A Judges Scientific company

Moorfield Nanotechnology Limited.

Unit 1 Wolfe Close, Parkgate Industrial Estate, Knutsford, Cheshire. United Kingdom. WA16 8XJ.

Company reg 3044718 VAT reg GB 616 3241 66

Phone +44 (0)1565 722609
Web moorfield.co.uk
Email sales@moorfield.co.uk

Distributed by